

# SWAPHelper.COM EATC MOD SERVICE

## BY NENTEC CORPORATION

**Blue** – Left side, Blue LED+ (Connect to **positive** to turn on)

**Orange** – Left side, Red LED+ (Connect to **positive** to turn on)

**White** – Right side, Blue LED+ (Connect to **positive** to turn on)

**Red** – Right side, Red LED+ (Connect to **positive** to turn on)

**Brown** – Left Seat Button, pulls to **ground** when pressed, **current limit 75 milliamps**

**Green** – Right Seat Button, pulls to **ground** when pressed, **current limit 75 milliamps**

**\*\*Note about seat buttons – if you connect them to relays, you MUST put a diode across the relay coil or damage will result!!\*\*** See below:

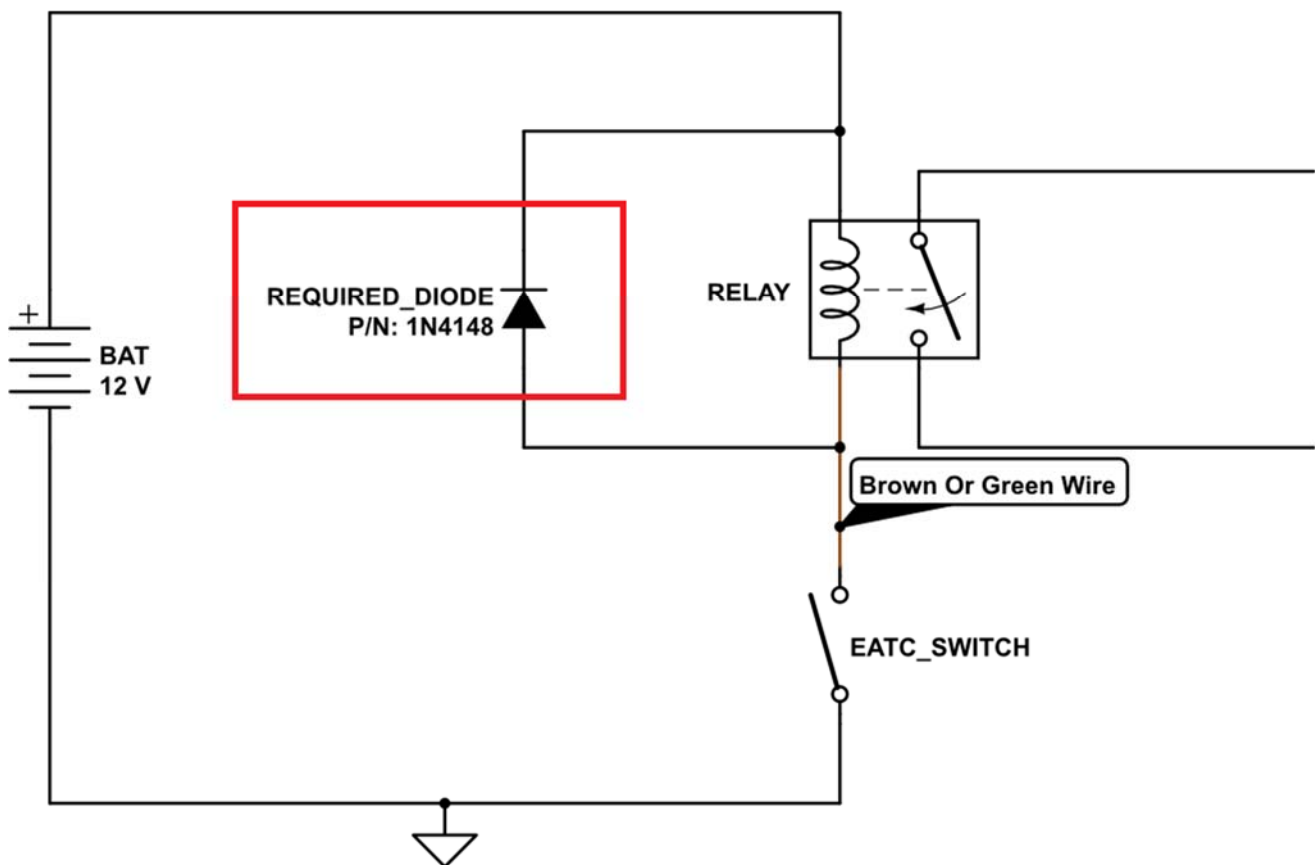

## For Excursion Rear Defrost:

These wires can be found at the original Rear Defrost switch (no longer used).

**Tan** – Rear Defrost Switch, connect to circuit 1010, Dark Blue/Orange

**Pink** – Rear Defrost Indicator LED, connect to circuit 59, Dark Green/Violet

### Excursion

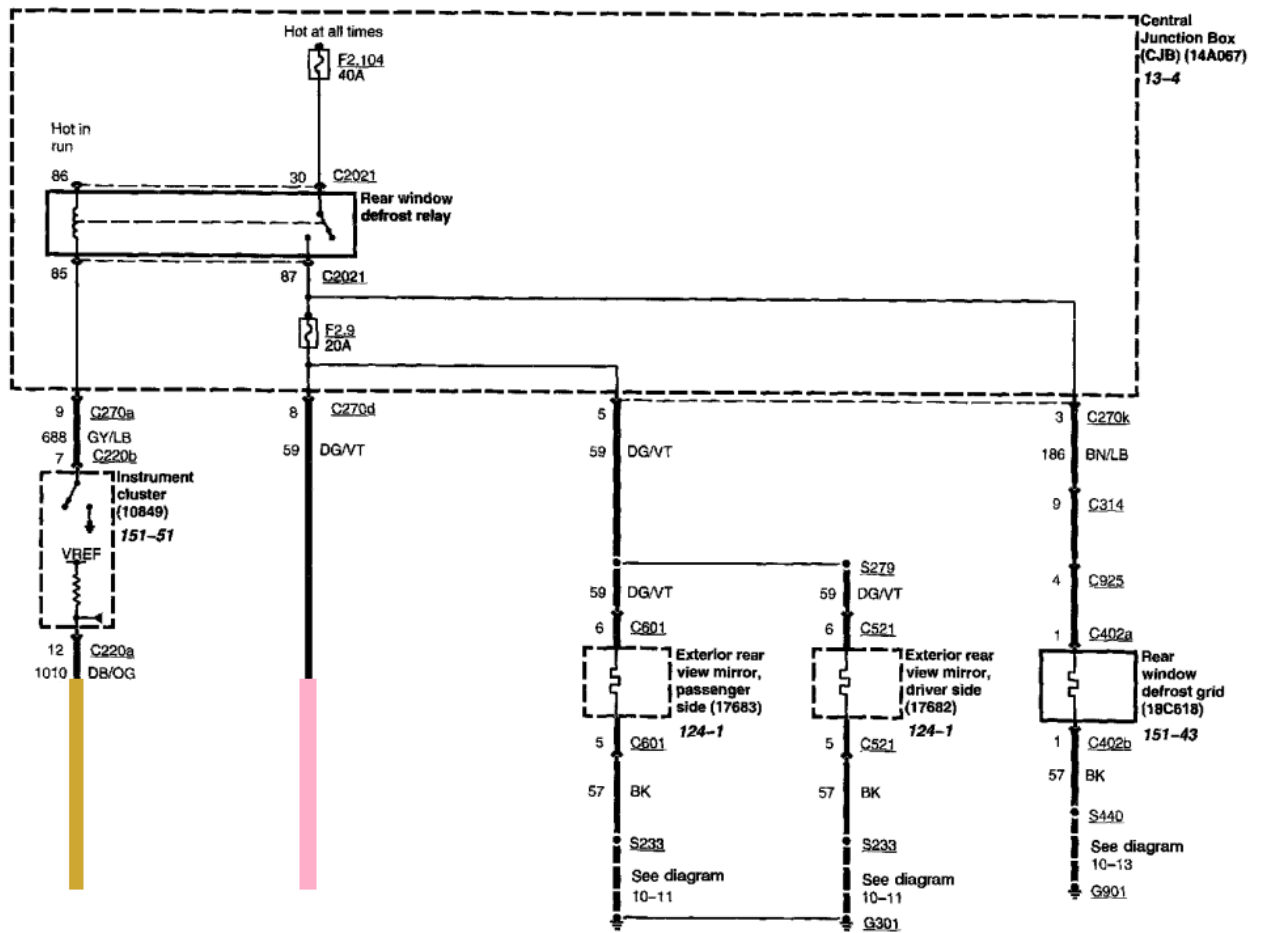

# ***SEAT HELPER* WIRING**

Connect EATC outputs to the Seat Helper 10 pin connector as follows:

## **From EATC**

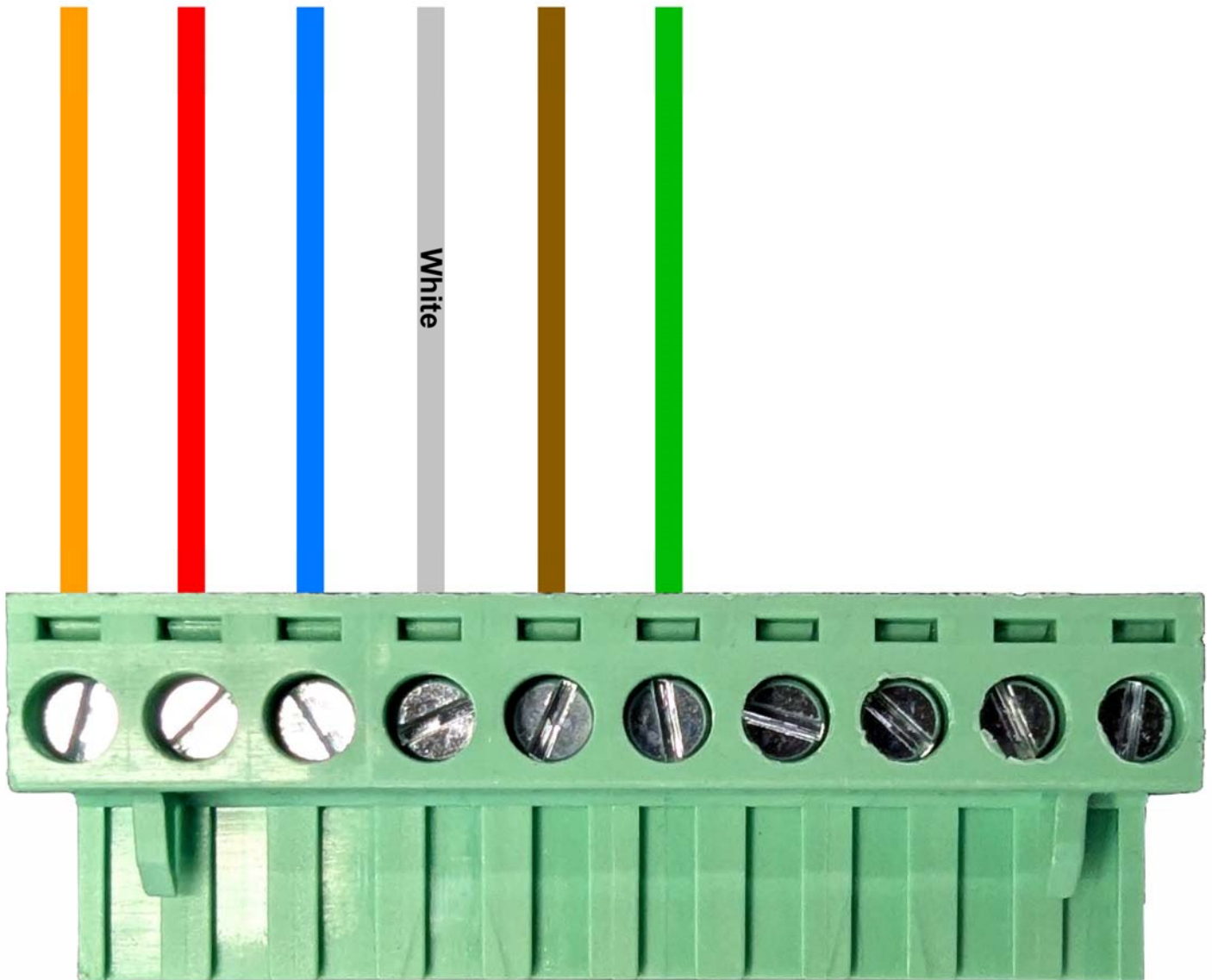

Make sure the Seat Helper and EATC have good grounding points (black wire on the Seat Helper, dash frame grounds for the EATC) to ensure proper functionality!

**Return Policy:**

**This product is not eligible for return but may be repaired or replaced under Warranty policy.**

**Warranty:**

**Nentec Corporation (SwapHelper.com) warrants the modified section of this product (screen and face functionality) to be free of defects in material and workmanship for one (1) year from date of purchase. This warranty is limited to the correction of any such defect, or the replacement of any such defective item, provided that: (a) item(s) was/were purchased from SwapHelper.com or an authorized Nentec Corporation distributor; (b) we are properly notified and consent to the return of the item(s) in question; (c) the item(s) is/are returned with proof of purchase date; and (d) it is found upon inspection by us that the item(s) is/are defective as noted above; (e) the return request is made by original purchaser. This warranty does not cover labor costs, consequential damages, nor does it apply to any item(s) that have been improperly installed, overloaded, altered, or otherwise abused by the customer, its agent(s) or employee(s). Other than the described obligation, we assume no further liability with respect to the sale or use of our products. We make no warranty, expressed or implied, and disclaim any warranty of merchantability or fitness for a particular purpose. Warranty requests must be made by requesting a Return Merchandise Authorization from [Contact@SwapHelper.com](mailto:Contact@SwapHelper.com).**